



CRST120

尺寸(Dimensions):73X54X82.5mm

特点 Features

- 1,防尘;
- 2,触点负载(100A-200A);
- 3,引出端形式和安装方式多;

订货信息 Ordering information

CRST 120 — A —DC12V

1 2 3

- 1,型号 Part number: CRST120
- 2,触点形式 Contact arrangement:A:1A;
- 3,线圈额定电压 Coil rated voltage(V):DC:6,12,24,36,48;

触点数据 Contact data

触点形式 Contact Arrangement	1A	
触点材料 Contact Material	AgSnO ₂ , AgCdO	
触点负载(阻性) Contact Rating(Resistive)	100A/14VDC 200A/14VDC	
最大切换功率 Max.Switching Power	1400VA	
最大切换电压 Max.Switching Voltage	30VDC	
触点阻性或压降 Contact Resistance or Voltage Drop	≤100mΩ	
寿命 Operation Life	电气 Electrical	1*10 ⁵
	机械 Mechanical	5*10 ⁴

线圈参数 Coil Parameter (23℃)

线圈电压 Coil voltage (VDC)		线圈电阻 Coil Resistance Ω ±10%	吸合电压 VDC(最大) Pick up Voltage VDC(Max)(额定电压 的 75%)(75% of rated voltage)	释放电压 VDC Release voltage VDC(Min) (额定电压的 5%) (5% of rated voltage)	线圈功耗 Coil power consumption (W)	动作时间 Operate Time (mS)	释放时间 Release Time (mS)
额定 Rated	最大 Max						
12	13.2	36	9.0	0.6	4.1	20	10

注意:1,使用的线圈电压低于线圈额定电压时将会损害继电器的工作.

2,吸合,释放电压仅供检测用,不是设计的使用指标.

Caution:1,The use of any coil voltage less than the rated coil voltage will compromise the operation of the relay.

2,Pick up and release voltage are for test purposes only and are not be used as design criteria.

技术特性 Operation condition

绝缘电阻 Insulation Resistance		100M Ω (DC500V)
介质耐压 Dielectric Strength	断开触点间 Between Contacts	500VAC 1min
	触点与线圈间 Between Contacts and Coil	500VAC 1min
耐冲击 Shock Resistance	耐久 Durable	20G min
	误动作 False action	200G min
抗振性 Vibration Resistance		10~55Hz 双振幅 Double amplitude 1.5mm
安装方式 Termination		快速链接 QC
环境温度 Ambient Temperature		-28.9~+48.9°C
相当湿度 Relative Humidity		5%~85% RH
质(重)量 Unit weight		Approx.170.5g

外形尺寸 Dimensions(mm/Inch)

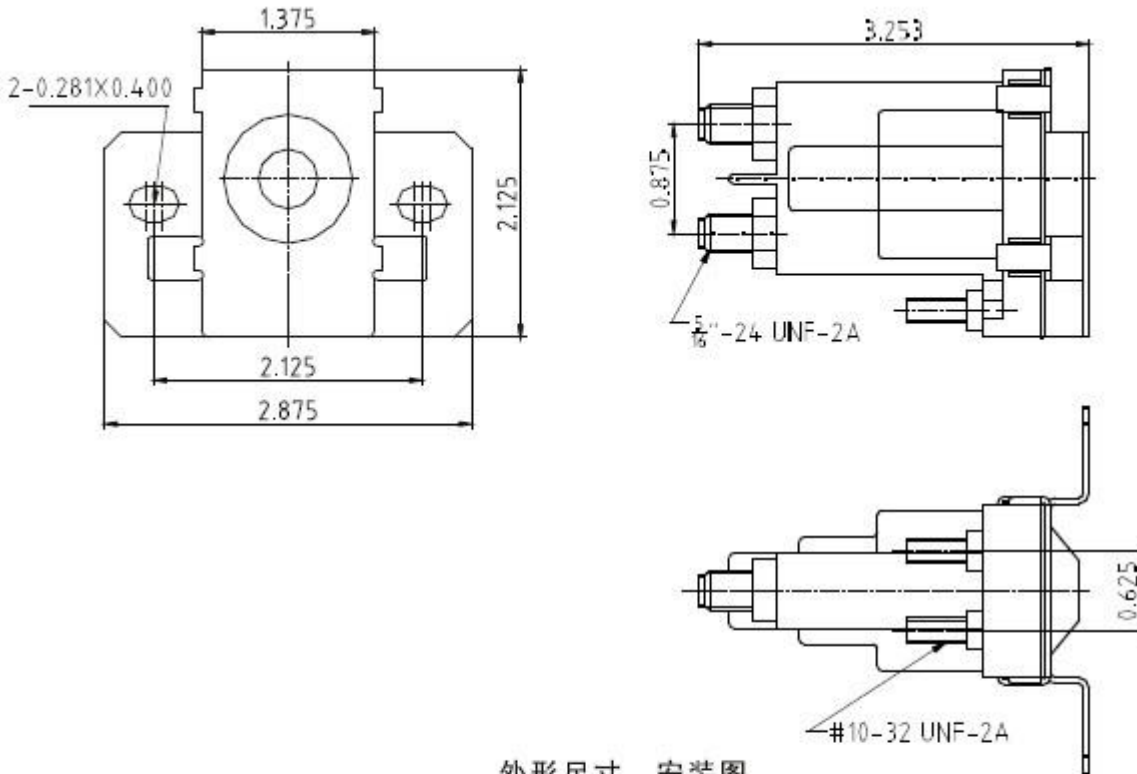

外形尺寸、安装图

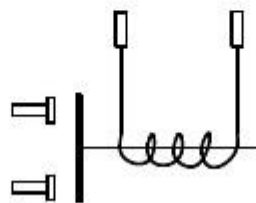

接线图